

开槽半沉头木螺钉

Slotted raised countersunk head wood screws

1 引言

本标准规定了公称直径为1.6~10mm的半沉头木螺钉。

2 引用标准

GB 922—86《木螺钉技术条件》。

3 尺寸

其余 6.3

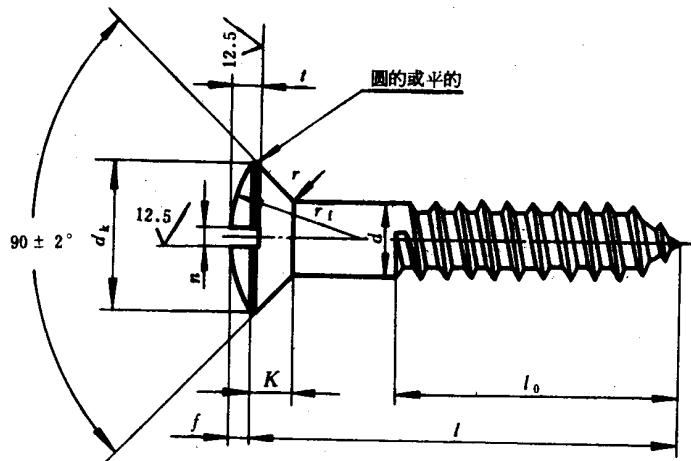

GB 101-86

mm

d	公称		1.6	2	2.5	3	3.5	4	(4.5)	5	(5.5)	6	(7)	8	10
	min	max	1.46	1.86	2.25	2.75	3.2	3.7	4.2	4.7	5.2	5.7	6.64	7.64	9.64
d _k	公称		3.2	4	5	6	7	8	9	10	11	12	14	16	20
	max	min	2.9	3.7	4.7	5.7	6.64	7.64	8.64	9.64	10.57	11.57	13.57	15.57	19.48
f	~		0.5	0.6	0.8	0.9	1.1	1.2	1.4	1.5	1.7	1.8	2.1	2.4	3
k	max		1	1.2	1.4	1.7	2	2.2	2.7	3	3.2	3.5	4	4.5	5.8
n	公称		0.4	0.5	0.6	0.8	0.9	1.0	1.2	1.2	1.4	1.6	1.8	2.0	2.5
	min	max	0.4	0.5	0.6	0.8	0.9	1.0	1.2	1.2	1.4	1.6	1.8	2.0	2.5
	~		0.65	0.75	0.85	1.05	1.15	1.35	1.55	1.55	1.75	1.95	2.15	2.35	2.85
r	~		0.2	0.2	0.2	0.2	0.4	0.4	0.4	0.4	0.4	0.4	0.5	0.5	0.5
r _f	~		2.8	3.6	4.3	5.5	6.1	7.3	7.9	9.1	9.7	10.9	12.4	14.5	18.2
t	max		0.96	1.06	1.3	1.5	1.84	1.94	2.4	2.6	2.8	2.9	3.4	3.7	4.76
	min		0.64	0.74	0.9	1.1	1.36	1.46	1.8	2.0	2.2	2.3	2.8	3.1	4.04
l			l ₀												
公称	min	max	公称	min	max										
6	5.25	6	4	3.3	4.7										
8	7.10	8	5	4.3	5.7										
10	9.10	10	6	5.3	6.7										
12	10.90	12	8	7.1	8.9										
14	12.90	14	9	8.1	9.9			商							
16	14.90	16	10	9.1	10.9										
18	16.90	18	12	10.9	13.1										
20	18.70	20	13	11.9	14.1				品						
(22)	20.70	22	14	12.9	15.1										
25	23.70	25	17	15.9	18.1										
30	28.70	30	20	18.7	21.3										
(32)	30.40	32	21	19.7	22.3				规						
35	33.40	35	23	21.7	24.3										
(38)	36.40	38	25	23.7	26.3										
40	38.40	40	26	24.7	27.3										
45	43.40	45	30	28.7	31.3						格				
50	48.40	50	33	31.4	34.6										
(55)	53.10	55	36	34.4	37.6										
60	58.10	60	40	38.4	41.6										
(65)	63.10	65	43	41.4	44.6						范				
70	68.10	70	46	44.4	47.6										
(75)	73.10	75	50	48.4	51.6										
80	78.10	80	52	50.1	53.9								围		
(85)	82.80	85	56	54.1	57.9										
90	87.80	90	60	58.1	61.9										
100	97.80	100	66	64.1	67.9										
120	117.80	120	80	78.1	81.9										

注：尽可能不采用括号内的规格。

4 技术条件

按GB 922-86规定。

5 标记

公称直径10mm、长度100mm、材料为A3、不经表面处理的开槽半沉头木螺钉的标记示例：
木螺钉 GB 101-86 10×100

附加说明：

本标准由中华人民共和国机械工业部提出，由机械工业部标准化研究所归口。

本标准由机械工业部标准化研究所负责起草。