

METRIC SELF-DRILLING TAPPING SCREWS

IFI-504
1997**IFI NOTES:**

1. *IFI-504 was originally published in 1976. Since that time several changes were made, all of which were incorporated in the 1982 edition. This latest edition (1997) includes additional changes to bring the standard current with existing practice.*
2. *An ISO standard for metric self-drilling screws is under development at this time and is currently identified as ISO/DP 10666.*

1. SCOPE

1.1 This standard covers requirements for metric steel self-drilling tapping screws suitable for use in general engineering applications.

The objective of this standard is to insure that self-drilling tapping screws, by meeting the mechanical and performance requirements specified, shall drill a hole and form or cut mating threads in materials into which they are driven, without deforming their own thread and without breaking during assembly.

Appendix A outlines assembly considerations for informational purposes.

NOTE — The performance requirements covered in this standard apply only to the combination of laboratory conditions described in the testing procedures. If other conditions are met in an actual service application (such as different materials, thicknesses, etc.) drilling speed, drill load, starting torque, failure torque, and driving time values may require adjustment.

1.2 **Designation.** The two types of self-drilling tapping screws for which characteristics are covered in this standard are designated Types BSD and CSD.

1.2.1 **BSD.** BSD screws have spaced threads and are available with drill points of varying configuration, designated Style 2 and Style 3, designed to accommodate different panel thickness conditions as outlined in Table 5.

1.2.2 **CSD.** CSD screws have threads of machine screw diameter-pitch combinations approximating a 60 deg basic thread form. CSD screws are not subject to thread gaging but shall meet the dimensional requirements of this standard. CSD screws are available with drill points of varying configuration, designated Style 2 and Style 3, designed to accommodate different panel thickness conditions as outlined in Table 5.

2. REQUIREMENTS**2.1 Material and Process Requirements**

2.1.1 **Material and Chemistry.** Screws shall be made from cold heading quality, killed steel wire conforming to the following chemical composition requirements:

Analysis (1)	Composition Limits (Percent by weight) (2)			
	Carbon		Manganese	
	Min	Max	Min	Max
Ladle	0.15	0.25	0.70	1.65
Check	0.13	0.27	0.64	1.71

1. Ladle analysis may be used for routine reporting. Check analyses shall be used in case of dispute or as required.
2. Boron is permitted in the range of 0.0005-0.003.

2.1.2 **Heat Treatment.** Screws shall be heat treated in a carbonitriding or gas carburizing system.

IFI-504
1997

METRIC SELF-DRILLING TAPPING SCREWS

TAPPING
SCREWS

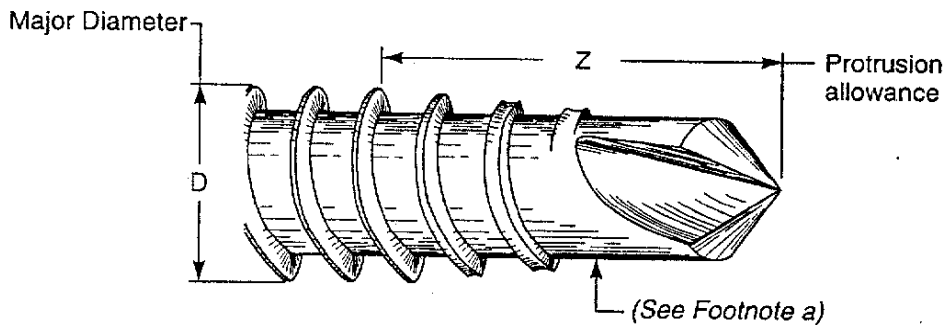

Table 1 Dimensions of Threads and Points for Types BSD and CSD Self-Drilling Tapping Screws
Type BSD

Nom Screw Size	Thread Pitch	D Major Dia		d Minor Dia		(b) Z Protrusion Allowance (Ref)		L Minimum Practical Nom Screw Length (Ref)							
		Max	Min	Max	Min	Style 2 Point	Style 3 Point	Style 2 Points (c)				Style 3 Points (c)			
								Formed		Milled		Formed		Milled	
								Pan & Hex Washer Heads	Flat & Oval CTSK Heads	Pan & Hex Washer Heads	Flat & Oval CTSK Heads	Pan & Hex Washer Heads	Flat & Oval CTSK Heads	Pan & Hex Washer Heads	Flat & Oval CTSK Heads
2.9	1.06	2.90	2.79	2.18	2.08	4.1	—	8	9.5	9.5	11	—	—	—	—
3.5	1.27	3.53	3.43	2.64	2.51	4.8	5.6	8	9.5	9.5	11	—	—	—	—
4.2	1.41	4.22	4.09	3.10	2.95	5.4	6.4	9.5	11	11	12.5	9.5	11	11	12.5
4.8	1.59	4.80	4.65	3.58	3.43	6.0	7.6	11	12.5	12	15	12.5	14	14	16.5
5.5	1.81	5.46	5.31	4.17	3.99	7.0	9.0	12.5	16	13.5	16.5	12.5	16	16.5	20
6.3	1.81	6.25	6.10	4.88	4.70	8.1	10.0	12.5	16	13.5	17.5	12.5	16	17.5	21.5

Type CSD

Nom Screw Size	Thread Pitch	D Major Dia		(b) Z Protrusion Allowance (Ref)		L Minimum Practical Nom Screw Length (Ref)							
		Max	Min	Style 2 Point	Style 3 Point	Style 2 Points (c)				Style 3 Points (c)			
						Formed		Milled		Formed		Milled	
						Pan & Hex Washer Heads	Flat & Oval CTSK Heads	Pan & Hex Washer Heads	Flat & Oval CTSK Heads	Pan & Hex Washer Heads	Flat & Oval CTSK Heads	Pan & Hex Washer Heads	Flat & Oval CTSK Heads
3	0.5	3.00	2.87	4.8	—	9.5	11.0	11.0	12.7	—	—	—	—
3.5	0.6	3.50	3.35	5.4	6.3	9.5	11.0	11.0	12.7	11.0	12.7	12.7	14.0
4	0.7	4.00	3.84	5.9	7.3	11.0	12.7	12.7	14.0	13.5	15.0	15.0	16.7
5	0.8	5.00	4.83	6.7	8.2	12.7	14.0	13.5	16.7	14.0	16.0	16.0	18.3
6	1.0	6.00	5.80	9.9	11.6	16.0	19.0	16.7	19.8	15.0	18.3	19.8	23.0

NOTES:

- Drill portion of points may be milled and/or cold formed and details of point taper and flute design shall be optional with the manufacturer, provided the screws meet the performance requirements specified in this standard and are capable of drilling the maximum panel thicknesses shown in Table 5 prior to thread pick-up.
- Protrusion allowance Z is the distance, measured parallel to the axis of screw, from the extreme end of the point to the first full form thread beyond the point and encompasses the length of drill point and the tapered incomplete threads. It is intended for use in calculating the maximum effective design grip length Y on the screw in accordance with the following: $Y = L \text{ min} - Z$.
- Style 3 points have larger diameters and longer flutes than Style 2 in order to accommodate the drilling and tapping of thicker materials.
- All dimensions are in millimeters.



METRIC SELF-DRILLING TAPPING SCREWS

2.1.3 Tempering Temperature. Minimum tempering temperature shall be 330°C.

2.1.4 Finish. Screws may be furnished plain or with a protective coating (electrodeposited or mechanical plating or chemical conversion coating) as specified by the user. At the option of the manufacturer screws may be provided with an additional supplementary lubricant as necessary to meet the performance requirements.

Electroplated screws shall be baked for a minimum of four hours at a temperature of 204°C with an allowable load temperature tolerance of $\pm 10^\circ\text{C}$ within one hour after plating to reduce the risk of hydrogen embrittlement.

In cases where screws are plated or coated following delivery to the purchaser (or where plating or coating of screws is otherwise under the control of the purchaser), the screw producer shall not be responsible for failure of the screws to meet mechanical or performance requirements due to plating or coating. In such cases, additional screws from the same lot shall be stripped of plating or coating, baked, lubricated with machine oil and retested in the natural finish.

2.2 Dimensional Requirements

2.2.1 Head Types. The head types covered by this standard are flat countersunk, oval countersunk, pan and hex washer. Head dimensions shall conform to those specified in ASME B18.6.5M.

2.2.2 Washer Thickness. Dimensions are specified in Table 2.

Slotted head screws are not recommended for self-drilling screws. However, catcher arrangements which hold the screws by the shank can be used successfully with these head types.

2.2.3 Recesses. Head recesses shall be Type I or Type IA with dimensions as specified in ASME B18.6.5M.

2.2.4 Positional Tolerances. The positional relationship between the heads and driving provisions of screws and the shanks of screws (formerly defined as Eccentricity) shall be as follows:

2.2.4.1 Position of Hex Washer Heads. The axis of the hex washer head shall be located at true position relative to the axis of the screw shank within a tolerance zone having a diameter equivalent to 6 percent of the basic screw diameter.

2.2.4.2 Position of Recess. The recess in cross recessed head screws shall be located at true position relative to the axis of the screw shank within a tolerance zone having a diameter equivalent to 6 percent of the basic screw diameter.

2.2.5 Length

2.2.5.1 Measurement. The length of screw shall be measured parallel to the axis of the screw from the extreme point to the largest diameter of the bearing surface of the head.

2.2.5.2 Tolerance on Length. The tolerance on length of screws shall conform to the following:

Nom Screw Length	Tolerance on Length
Up to 20 mm incl.	- 0.75 mm
Over 20 mm to 40 mm	- 1.25 mm
Over 40 mm	- 1.50 mm

2.2.6 Points. Points for BSD and CSD screws shall be such as to insure that specified performance requirements are met.

IFI-504
1997

METRIC SELF-DRILLING TAPPING SCREWS

TAPPING
SCREWS

2.2.7 Thread Dimensions. Dimensions of Types BSD and CSD screw threads and points shall conform to those given in Table 1.

2.2.8 Length of Thread

2.2.8.1 Type BSD Screws. For screws of nominal lengths equal to or shorter than 40 mm, the full form threads shall extend close to the head such that the specified minor diameter limits are maintained to within one pitch (thread), or closer if practicable, of the underside of the head. See Fig. 1. For screws of nominal lengths longer than 40 mm, the length of full form thread shall be as specified by the purchaser.

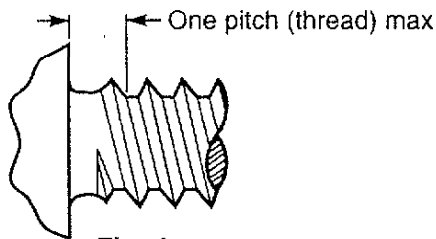

Fig. 1

2.2.8.2 Type CSD Screws. For screws of nominal lengths equal to or shorter than 40 mm, the full form threads shall extend close to the head such that the specified major diameter limits are maintained to within two pitches (threads), or closer if practicable, of the underside of the head. See Fig. 2. For screws of nominal lengths longer than 40 mm, the length of full form thread shall be as specified by the purchaser.

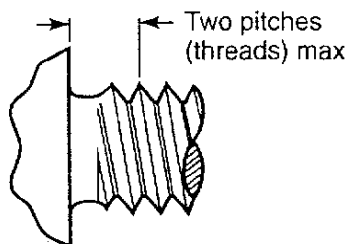

Fig. 2

2.3 Mechanical and Performance Requirements

2.3.1 Hardness

2.3.1.1 Core Hardness. Screws shall have a core hardness of Rockwell C 32-40, when tested as specified in 3.1.

2.3.1.2 Surface Hardness. Screws shall have a case hardness of Rockwell C 50-56, when tested as specified in 3.2.

2.3.1.3 Total Case Depth. Screws shall have a total case depth conforming to the following, when tested as specified in 3.3.

Nom Screw Size mm	Total Case Depth (mm)	
	Min	Max
2.9 thru 3.5	0.05	0.18
4 thru 5.5	0.10	0.23
6 and 6.3	0.13	0.28

2.3.2 Torsional Strength. Screws shall not fail with the application of a torque less than the torsional strength torque specified in Table 3, when tested in accordance with 3.4.

2.3.3 Drill-Drive Test. Screws shall meet the requirements of the time to drill and thread a hole completely through a test plate as specified in Table 4, when tested in accordance with 3.5.

2.3.4 Ductility. Heads of screws shall not separate completely from the shank when a permanent deformation of 5 deg is induced between the plane of the underhead bearing surface and plane normal to the axis of the screw, when tested in accordance with 3.6.

2.3.5 Hydrogen Embrittlement. Electroplated screws shall withstand without evidence of failure the hydrogen embrittlement torque specified in Table 3 for the applicable screw size and finish, when tested in accordance with 3.7.

METRIC SELF-DRILLING TAPPING SCREWS

IFI-504
1997

Fig. 3

NOTE 1: The chamfer on the periphery of the head is at the manufacturer's option.

Table 2 Washer Thickness Dimensions

Nom Screw Size	U	
	Washer Thickness	
	Max	Min
2.9	0.75	0.50
3	1.00	0.60
3.5	1.00	0.60
4	1.25	1.00
4.2	1.25	1.00
4.8	1.25	1.00
5	1.25	1.00
5.5	1.25	1.00
6	1.50	1.00
6.3	1.50	1.00

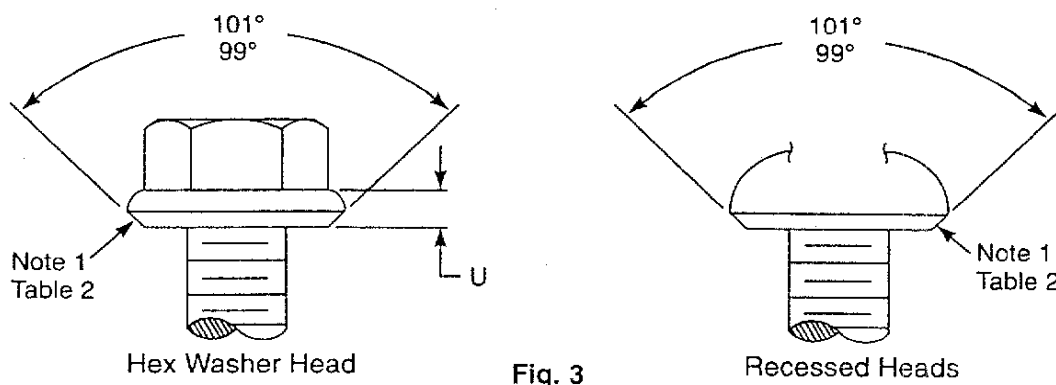
3. TEST METHODS

3.1 Core Hardness. Core hardness shall be determined at mid-radius of a transverse section through the screw taken at a distance sufficiently behind the point of the screw to be through the full minor diameter.

3.2 Surface Hardness. For routine testing or a quick check, the surface hardness may be checked by using the HR15N scale providing

the product and testable area are suitable. For arbitration purposes, the preferred method is to check hardness using a knoop or pyramid indenter and a 500 gram load on a properly prepared longitudinal section. Hardness readings shall be taken 0.051 mm below the surface at the midpoint between the crest and root. For those specimens where the total case is 0.10 mm or less the readings may be taken 0.025 mm below the surface using a 100 gram load.

IFI-504
1997**METRIC SELF-DRILLING TAPPING SCREWS****TAPPING
SCREWS****Table 3 Mechanical and Performance Requirements for
Types BSD and CSD Self-Drilling Tapping Screws**

Nom Screw Size	Torsional Strength Min N-m		Hydrogen Embrittlement Test Torque N-m	
			Zinc Plated Screws	
	Type BSD	Type CSD	Type BSD	Type CSD
2.9	1.6	—	1.3	—
3	—	2.2	—	▶
3.5	2.7	3.5	2.3	▶
4	—	5.2	—	▶
4.2	4.7	—	4.6	—
4.8	6.9	—	6.2	—
5	—	10.5	—	▶
5.5	10.4	—	9.6	—
6	—	17.7	—	▶
6.3	16.9	21	14.9	▶

▶ Values are under development.

For the purpose of measuring surface hardness, the readings will be taken on specimens which have been sectioned in a tolerance zone from true center to above center in order to provide adequate support in the mounting media. When measuring the apparent major diameter on the sectioned metallographic specimen, the apparent major diameter shall be no less than 95% of the minimum major diameter permitted for the size of product being checked.

3.3 Total Case Depth. Total case depth is the distance measured perpendicularly from the surface of a hardened case to a point where the differences in chemical or physical properties of the case and core no longer can be distinguished. Total case depth shall be measured at a mid point between crest and root on the thread flank. The recommended method for measuring total case depth is to check it in the

hardened condition in accordance with SAE J423 Para. 5.3.1 using a magnification of 100X.

3.4 Torsional Strength Test. The sample screw shall be securely clamped by suitable means (see Fig. 3 of B18.6.5M) such that the threads in the clamped length are not damaged, and that at least two full threads project above the clamping device, and that at least two full threads exclusive of point, flutes or thread cutting slot, are held within the clamping device. By means of a suitably calibrated torque measuring device, torque shall be applied to the screw until failure of the screw occurs. The torque required to cause failure shall be recorded as the torsional strength torque.

3.5 Drill-Drive Test. Sample screws shall be selected at random from the lot and shall be used to drill holes and form or cut mating threads



METRIC SELF-DRILLING TAPPING SCREWS

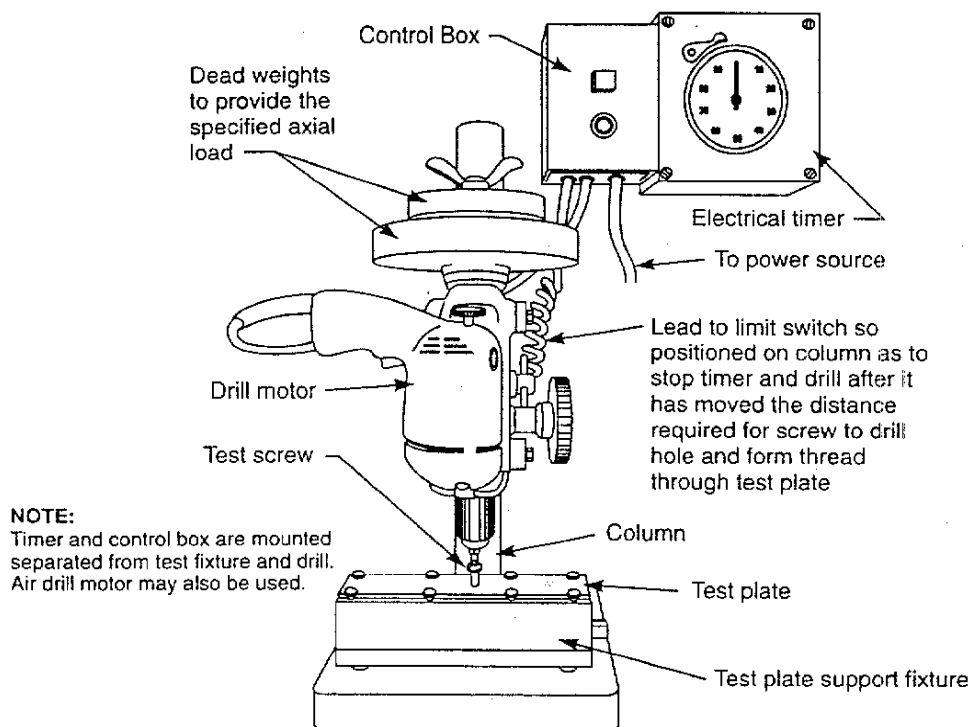

Fig. 4 Typical Drill-Drive Test Fixture

Table 4 Drill-Drive Test Conditions and Requirements for Types BSD and CSD Self-Drilling Tapping Screws

Nom Screw Size	(a) Test Plate Thickness		(b) Axial Loading N			Time to Drill & Form Thread (Seconds)
			A	B	C	
	Max	Min	Max	Max	Max	Max
2.9	1.62	1.52	110	135	180	2.0
3	1.62	1.52	110	135	180	2.0
3.5	1.62	1.52	135	155	200	2.5
4	1.62	1.52	135	155	200	3.0
4.2	1.62	1.52	135	155	200	3.0
4.8	1.62	1.52	155	180	220	3.5
5	1.62	1.52	155	180	220	3.5
5.5	1.62	1.52	200	220	270	4.0
6	1.62	1.52	200	220	270	4.5
6.3	1.62	1.52	200	220	270	5.0

NOTES:

- a. Test plates shall be low carbon cold rolled steel having a hardness of Rockwell B60 to B85.
- b. Axial loads are varied to offset the detrimental effects on drilling capability created by finishes applied to screws in accordance with the following:
 Column A — Axial loads tabulated shall apply to plain, oiled, and commercial phosphate coating and zinc plating up to 7.5 µm thickness.
 Column B — Axial loads tabulated shall apply to special electroplated finishes exceeding 7.5 µm thickness and to special coatings, such as thread sealing hot melts, etc.
 Column C — Axial loads tabulated shall apply to chromium finish.
- c. Tool speed shall be 2500 rpm for screw sizes 2.9 thru 5 mm. Tool speed of 1800 rpm is recommended for screw sizes 5.5 mm to 6.3 mm, however, 2500 rpm may be used provided care is exercised to minimize influence of high heat build-up due to surface speed. (NOTE: These speeds are for test purposes and are not necessarily suited for all service applications. Refer to Appendix A, Para. (E) and to special note in Scope, Para. 1.1.)



IFI-504
1997

METRIC SELF-DRILLING TAPPING SCREWS

TAPPING
SCREWS

in a test plate. The time in seconds for the screw to drill and thread a hole completely through the test plate shall be recorded. The test plate material and thickness, and load applied against the screw during drilling and threading, and the other test conditions are specified in Table 4. Each screw shall be used to drill and thread only one hole. A typical drill-drive test fixture is shown in Fig. 4.

The drive test shall be conducted in accordance with the following sampling plan:

Lot Size	Sample Size
Up to 5,000	6
5,001 to 15,000	12
15,001 to 50,000	18
50,001 and over	25

If the actual time for each of the sample screws to drill and thread a hole does not exceed the maximum time specified in Table 4, the lot shall be acceptable. If one or more of the times exceed the maximum specified in Table 4, a retest shall be made using twice the original sample size. The lot shall then be acceptable in accordance with the following:

Sample Size	Slow Drive (1)	Excessive Drive (2)
12	1	0
24	1	0
36	2	1
50	3	1

NOTES:

1. A "Slow Drive" is defined as a screw having a drilling and threading time in excess of but less than twice the specified maximum.
2. An "Excessive Drive" is defined as a screw having a drilling and threading time twice the specified maximum or greater.

3.6 Ductility. The sample screw shall be inserted into a drilled hole in a hardened wedge block, or other suitable device, and an axial compressive (or impact) load applied against the top of the screw head. Loading shall be continued

until the plane of the underhead bearing surface is bent permanently through 5 deg with respect to a plane normal to the axis of the screw.

3.7 Hydrogen Embrittlement Test. Sample screws shall drill their own hole and form a thread in a steel test plate with a thickness equal to the maximum specified for the applicable screw type and size in Table 5. The head of the screw shall be seated against one or more plain washers as given in 3.7.1 (size corresponding to screw size and minimum stack thickness corresponding to maximum unthreaded length under the head) or an equivalent spacer and tightened with a torque equal to the hydrogen embrittlement torque specified in Table 3. The assembly shall remain in this tightened state for 24 hours. The original hydrogen embrittlement torque shall then be reapplied following which the screw shall be removed by the application of removal torque.

3.7.1 Underhead Bearing Test Surface. The surface condition of plain commercially available flat washers is normally suitable for the test specified in 3.7. For referee purposes, the surface shall conform to 0.50 to 0.75 μm (AA roughness range).

3.8 Torque Wrenches. Torque wrenches used in all tests shall be accurate within plus or minus 2 percent of the maximum of the specified torque range of the wrench.

Alternatively, a torque sensing power device of equivalent accuracy may be used.

4. INSPECTION

4.1 Inspection and Quality Assurance. Unless otherwise specified by the purchaser in the original inquiry and purchase order, acceptability shall be based on conformance with the requirements specified in ANSI B18.18.1M, page L-5.



METRIC SELF-DRILLING TAPPING SCREWS

IFI-504
1997Table 5 Self-Drilling Tapping Screw
Selection Chart

Screw Type	Point Style	Nom Screw Size	P (a)
			Recommended Panel Thickness, mm
BSD and CSD	2	2.9 and 3	2.0 max
		3.5	2.3 max
		4 and 4.2	2.5 max
		4.8 and 5	2.8 max
	3	5.5	3.6 max
		6	4.0 max
3	3	6.3	4.4 max
		3.5	2.3-2.8
		4 and 4.2	2.5-3.6
		4.8 and 5	2.8-4.4
		5.5, 6, 6.3	2.8-5.3

NOTE:

- a. If the panel to be drilled is comprised of two or more layers, see Figs. 5B and 5C, the gap between the layers (which might consist of a sealing strip, air space caused by warpage, etc., or just the separation caused by the pressure exerted by the driver) must be considered in determining the point style for the particular fastener. Using a self-drilling tapping screw as covered in this standard in a multi-layer application with an excessive gap, could result in point breakage since the tapping in one layer begins before completion of the drilling of the other layers and since the advancement of the screw in the tapping operation is much faster than in the drilling operation.

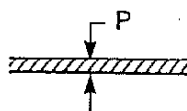
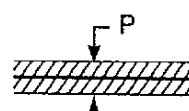
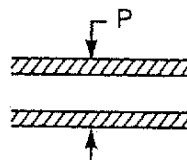
Fig. 5A —
Single panelFig. 5B —
Double panelFig. 5C —
Spaced panel

IFI-504
1997

METRIC SELF-DRILLING TAPPING SCREWS

TAPPING
SCREWS

APPENDIX A

ASSEMBLY CONSIDERATIONS

A. Screw Selection Chart. Table 5 represents a screw selection chart recommending panel thicknesses which can be fastened with various screw types and sizes.

B. Bits and Sockets. Magnetic bits and sockets are not recommended for sealing applications or when material thicknesses are near the maximum drilling limit of the particular screw (see Table 5), because of possible chip collection around the area being sealed and in the socket.

C. Driving Technique. End pressures of 110 to 290 N are required for efficient drilling of self-drilling tapping screws. Excessive pressure, especially during the initial penetration of the drill point, increases the amount of material being removed by the flutes and could result in drilling torques in excess of the strength of the drill point.

For applications involving several layers of material, certain design considerations must be made.

If one of the layers has a clearance hole, this hole size must be larger than the drill diameter and preferably larger than the screw thread major diameter. Clearance holes smaller than the drill point diameter result in a concentrated load on the edge of the point which results in

the same problems associated with excessive pressures.

If both layers (or several layers) are to be drilled, the gap between the layers (which might consist of a sealing strip, air space caused by warpage, etc., or just the separation caused by the pressure exerted by the driver) must be considered in determining the unthreaded point length for the particular fastener. Using a self-drilling tapping screw as covered in this standard in a multi-layer application with an excessive gap could result in point breakage since the tapping in one layer begins before completion of the drilling of the other layers and since the advancement of the screw in the tapping operation is much faster than in the drilling operation. The net result would be the same as when exerting excessive pressure.

D. Torque Output. Torque output of the driver should be equivalent to the torque required to drive a comparable standard thread forming or thread cutting tapping screw in a pre-drilled hole.

E. Driving Speed. Driving tools which operate between 2000 and 3000 rpm are satisfactory for most applications. Driving speed should be consistent with good drilling practice when using carbon steel drills.