

UDC 621.882.449 : 621.882.2

December 1990

## Curved spring washers for screw and washer assemblies

# DIN 6904

Federscheiben für Kombi-Schrauben

Supersedes December 1972 edition.

*In keeping with current practice in standards published by the International Organization for Standardization (ISO), a comma has been used throughout as the decimal marker.*

Dimensions in mm

### 1 Scope and field of application

Curved spring washers as specified in this standard are intended for use with screw and washer assemblies as specified in DIN 6900 Part 2. They are designed for use with bolted connections with bolts of a property class below 5.8 (as specified in ISO 898 Part 1). Curved spring washers are intended to counteract loosening of such connections (e.g. as a result of setting) (cf. DIN 267 Part 26). They do not effectively prevent loosening of the connection under varying radial load and are thus designed for use with short screws predominantly subject to thrust.

### 2 Dimensions

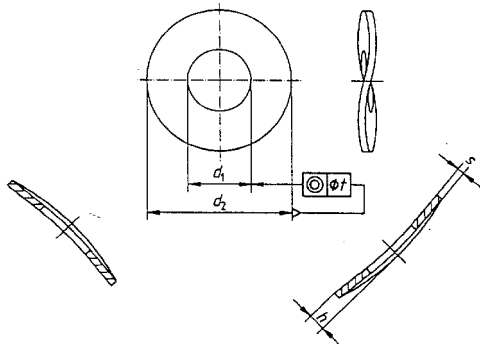

Table.

Nom- inal size	$d_1$ <sup>3)</sup>		$d_2$ <sup>3)</sup>		$s$			$h$		$t$	Approximate mass (7,85 kg/dm <sup>3</sup> ), per 1000 units, in kg	For thread size <sup>4)</sup>
	min. = nom- inal size	max.	max. = nom- inal size	min.	Nom- inal size	min.	max.	min.	max.	$\frac{1}{2}$ , IT 14		
2,25 <sup>1)</sup> 2)	2,25	2,35	7	6,78	0,5	0,45	0,55	0,9	1,05	0,18	0,13	M2,5
2,7 <sup>1)</sup>	2,7	2,8	8	7,78	0,5	0,45	0,55	0,9	1,05	0,18	0,17	M3
3,2 <sup>1)</sup>	3,2	3,32	8	7,78	0,5	0,45	0,55	1	1,15	0,18	0,16	M3,5
3,6	3,6	3,72	9	8,78	0,8	0,74	0,86	1,5	1,65	0,18	0,34	M4
4,55	4,55	4,67	11	10,73	0,8	0,74	0,86	1,6	1,75	0,215	0,49	M5
5,4	5,4	5,52	12	11,73	0,8	0,74	0,86	1,85	2	0,215	0,57	M6
7,3	7,3	7,45	15	14,73	1	0,93	1,07	2,2	2,4	0,215	1,06	M8
9,2	9,2	9,35	21	20,67	1	0,93	1,07	2,4	2,6	0,26	2,20	M10

<sup>1)</sup> For this size, no specifications have been made for the residual spring force in DIN 267 Part 26.

<sup>2)</sup> For this size, no specifications have been made for permanent set in DIN 267 Part 26.

<sup>3)</sup> The tolerances specified apply to the washer in the flat-pressed condition.

<sup>4)</sup> As specified in DIN 267 Part 26.

Continued on page 2

Page 2 DIN 6904

**3 Technical delivery conditions**

Washers shall be made of spring steel (FSt) and comply with the technical delivery conditions specified in DIN 267 Part 26.

**4 Designation**

Designation of a curved spring washer of nominal size 9,2, made of spring steel (FSt)<sup>1)</sup>:

Washer DIN 6904 – 9,2 – FSt

The DIN 4000-3-3 tabular layout of article characteristics shall apply for washers as covered in this standard.

**Appendix A****Additional washers (6,5) for replacement and maintenance purposes**

Thread size M 7 is not included in the international range of threads for screws and nuts and its further use is deprecated. However, with regard to existing documentation and for meeting replacement and maintenance requirements, washers for use with M 7 screw and washer assemblies may still be ordered on the basis of DIN 6904, December 1972 edition. The dimensions of such washers shall be as specified in the table below.

Table A.1.

Clearance hole diameter, $d_1$ (H12 <sup>1)</sup> )	For thread size	$d_2$  h13	$s$  Limit deviations	$h$		$t$	Approximate mass (7,85 kg/dm <sup>3</sup> ), per 1000 units, in kg
				min.	max.		
6,5	M7	14	1 ± 0,07	2,2	2,4	0,3	1,00

<sup>1)</sup> Relates to the actual minimum dimension of the finished washer.

**Standards referred to**

- DIN 267 Part 26 Fasteners; technical delivery conditions; steel spring lock washers for bolt/nut assemblies  
 DIN 4000 Part 3 Tabular layouts of article characteristics for washers  
 DIN 6900 Part 2 Screw and washer assemblies; coarse threaded screws with captive wave spring washer  
 ISO 898 Part 1 Mechanical properties of fasteners; bolts, screws and studs

**Previous editions**

DIN 6904: 09.66, 12.72.

**Amendments**

The following amendments have been made to the December 1972 edition.

- The 'Scope and field of application' clause has been included.
- Size 2,25 is now included.
- The dimensions of washers of nominal size 6,5 (for thread size M 7) have been specified in an appendix.
- Washers with  $d_1 = 9,3$  mm, with  $d_2 = 18$  mm, and with  $d_1 = 11$  mm for thread sizes M 10 and M 12, are no longer included.
- The specifications for  $d_1$ , and the nominal sizes have been amended.
- Limits of size have been specified.
- Tolerance  $t$  has been amended to comply with the specifications of DIN 137.
- The technical delivery conditions are no longer dealt with here but are given in DIN 267 Part 26.
- The standard has been editorially revised.

**International Patent Classification**

F 16 B 39/24

<sup>1)</sup> FSt steel shall also be used where no material is specified in existing documentation.